

# JAEGAR Ranger

## Long range camera platform with through shaft

The Jaegar Ranger is a ready to go surveillance system, ideal for long range surveillance applications. The addition of a fixed through shaft, running through the PT, allows the cameras to rotate 360° continuously while keeping a payload on top fixed in position, perfect to twin with radar.

Jaegar Ranger is perfect for long range surveillance applications and is offered with a proven Hi-res 640x480 DRS, 17µm VOx thermal module twinned with either a SD or HD video camera featuring a powerful optical zoom lens allowing the operator to both detect and then zoom into the area of interest. Both thermal and video outputs are provided simultaneously.

The robust aluminium housings are rated to IP67 and are anodised and powder coated to withstand harsh environmental conditions. The PT employs harmonic drive gearing with virtually zero backlash and the optical encoder ensures the unit retains position and will even self correct.

The Jaegar Ranger can easily be integrated within a larger security infrastructure and is the perfect partner for supporting radar systems

### Key features:

- HD or SD video cameras with powerful optical zoom lens
- Uncooled 6° 100mm thermal imaging camera
- IP or HD-SDI options
- One mast solution
- Virtually zero backlash
- Through shaft for mounting fixed platforms on top
- IP67 environmental protection (IP68 option)
- Absolute positioning feedback for radar control
- 360° continuous rotation
- Highly ruggedised for extreme environments
- Long range thermal detection
- Harmonic drive trains
- 45° per second pan speed



### The Silent Sentinel Range

Silent Sentinel offer an extensive range of camera and lens configurations to meet your exact surveillance requirements.

Contact customer service for more information on our full range of products and custom design and build services.

Tel: (1) 916-632-1301

[www.silentsentinel.com](http://www.silentsentinel.com)



OCULUS



AERON



OSIRIS



JAEGAR

## Jaegar standard and HD video range

Video type	SD	HD
Optical zoom	36x	30x
Digital enlargement	12x (432x combined)	12x (360x optical zoom)
Image sensors	1/4" Exview CCD	1/2.8" - Type Exmor CMOS sensor
Resolution	520TVL	Approx 3.27 million
Signal system	NTSC	HD: 1080p/SD: NTSC/PAL
Lens (wide to tele)	F=3.4mm to 122mm F1.6 to F4.5	f=4.3mm to 129mm F1.6 to F4.7
Angle of view - horizontal	58.° (W) to 1.7° (T)	54.1° (W) to 2.9° (T)
Minimum illumination (50IRE)	1.4 lux color, 0.01 lux mono	1.7 lux, 0.01 lux in High Sens Mode
Video output	Composite	Digital

## Jaegar thermal range

Video type	Thermal
Sensor type	Uncooled VOx Microbolometer
Pixel size	17µ
Spectral band	8-14µm
Thermal sensitivity	<50mK
Array format	640X480
Frames rates	9Hz, 30Hz
Image control	White hot, Black hot, Invert
Focus	Fixed, preset, Athermalised
Zoom	E-zoom 1-4, Region of interest
FOV	6° - 100mm f1.6
Video output	Composite

## Common features

IP rating	IP67
Actuation	Pan and tilt stepper motors
Position encoders	Optical encoders on pan and tilt motors
Repeatability	0.09°
Pan rotation	360° continuous
Pan speed	0.02° -> 45°/Sec*
Tilt speed	0.02° -> 45°/Sec*
Tilt range	+90° to -90°

Temperature range	-30°C up to +65°C (-40°C with optional heater) -22°F up to +149°F (-40°F with optional heater)
Power	28 - 32VDC 5.0Amps
Housing material	Cast aluminium
Housing finish	Xylan undercoat with epoxy powder finish
Fixings material	Stainless steel
Additional feature	Focal length dependent speed control Equipped with external fall protection *Subject to payload

## Ordering information

Product code	Product description
JPT-NRANGER-FB	Jaegar Ranger, Black
JPT-NRANGER-FW	Jaegar Ranger, White
JPT-HRANGER-FB	Jaegar HD Ranger, Black
JPT-HRANGER-FW	Jaegar HD Ranger, White

## Dimensions (in millimeters)

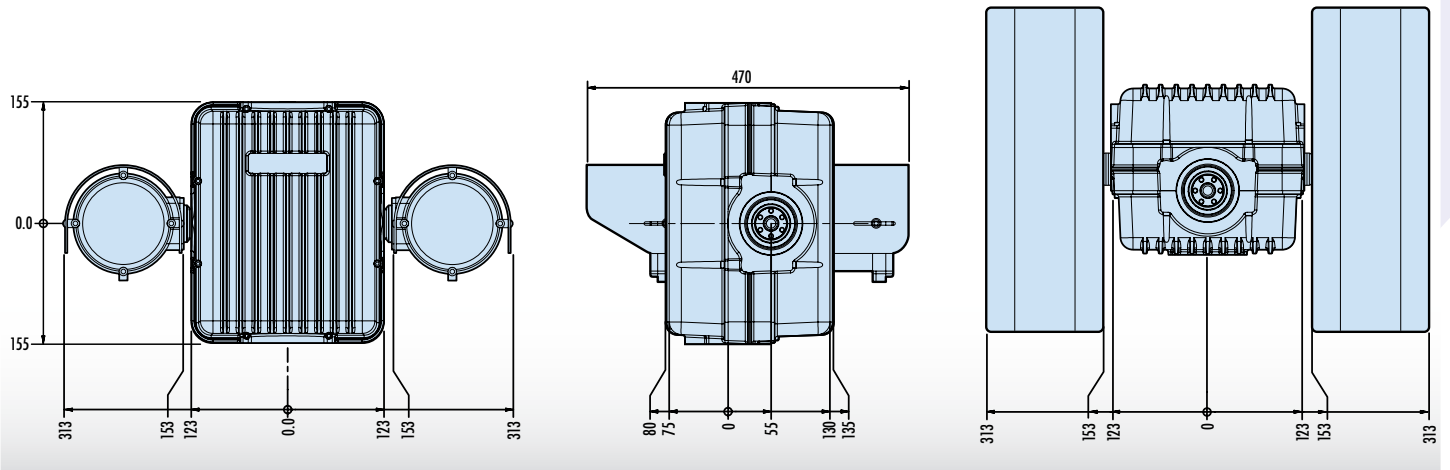

## Detection, Recognition and Identification range charts

DB type thermal

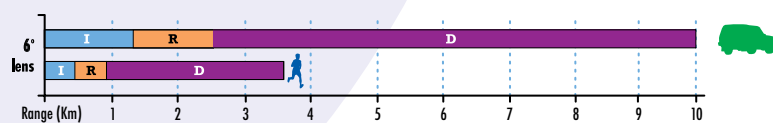

### Key to Johnson's Criteria charts

- D** Detection - an object is present (-2 pixels)
- R** Recognition - the object can be discerned (- 8 pixels)
- I** Identification - the object can be identified e.g. male versus female, a specific car (- 12.8 pixels)

Note: Ranges may vary depending on atmospheric conditions

## Tower mount bracket

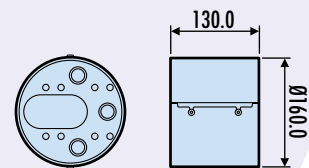

Specifications may be subject to change without notice • DA140814 - 1.1c • © 2014