

JAEGAR Searcher

Long range camera platform with through shaft

The Jaegar Searcher is a ready to go surveillance system, ideal for long range surveillance applications. The addition of a fixed through shaft, running through the PT, allows the cameras to rotate 360° continuously while keeping a payload on top fixed in position, perfect to twin with radar.

The Jaegar Searcher is offered with both a proven Hi-res 640x480 DRS, 17nm VOx thermal module twinned with either a SD or HD video camera. Both thermal and video cameras feature powerful optical zoom lens allowing the operator to both detect and then zoom into the area of interest. Both thermal and video outputs are provided simultaneously, ensuring nothing is missed.

The robust aluminium housings are rated to IP67 and are anodised and powder coated to withstand harsh environmental conditions. The PT employs harmonic drive gearing with virtually zero backlash and the optical encoder ensures the unit retains position and will even self correct.

The Jaegar Searcher can easily be integrated within a larger security infrastructure and is the perfect partner for supporting radar systems with top mounting allowing obstruction-free detection.

Key features:

- HD or SD video cameras with powerful optical zoom lens
- 2.8° - 24.5° 25-225mm thermal imaging camera with zoom
- IP or HD-SDI options
- One mast solution
- Virtually zero backlash
- Through shaft for mounting fixed platforms on top
- IP67 environmental protection (IP68 option)
- Absolute positioning feedback for radar control
- 360° continuous rotation
- Highly ruggedised for extreme environments
- Long range thermal detection
- Harmonic drive trains
- 45° per second pan speed



The Silent Sentinel Range

Silent Sentinel offer an extensive range of camera and lens configurations to meet your exact surveillance requirements.

Contact customer service for more information on our full range of products and bespoke design and build services.

Tel: + 44 (0)1992 558 093

www.silentsentinel.com



OCULUS



AERON



OSIRIS



JAEGAR

Jaegar standard and HD video range

Video type	SD	HD
Optical zoom	33x	33x
Image sensors	1/2" CCD	1/3" 2 MP
Resolution	560TVL	900 TVL
Signal system	PAL	Digital
Lens (wide to tele)	f=16mm - 528mm	f=15mm - 500mm
Angle of view - horizontal	22° (W) to 0.7° (T)	23.4° (W) to 0.74° (T)
Minimum illumination (SOIRE)	0.1 lux (+1.4)	1.6 lux
Video output	Composite	Digital

Jaegar thermal range

Video type	Thermal
Sensor type	Uncooled VOx Microbolometer
Pixel size	17µ
Spectral band	8-14µm
Thermal sensitivity	<50mK
Array format	640x480
Frames rates	9Hz, 25Hz
Image control	White hot, Black hot, Invert
Focus	Fixed, preset, Athermalised
Optical zoom	9x
FOV	2.8° - 24.5° 25-225mm f/1.5
Video output	Composite

Common features

IP rating	IP67
Actuation	Pan and tilt stepper motors
Position encoders	Optical encoders on pan and tilt motors
Repeatability	0.09°
Pan rotation	360° continuous
Pan speed	0.02° -> 45°/Sec*
Tilt speed	0.02° -> 45°/Sec*
Tilt range	+90° to -90°

Temperature range	-30°C up to +65°C (-40°C with optional heater) -22°F up to +149°F (-40°F with optional heater)
Power	28 - 32VDC 5.0 Amps
Housing material	Cast aluminium
Housing finish	Xylan undercoat with epoxy powder finish
Fixings material	Stainless steel
Additional feature	Focal length dependent speed control Equipped with external fall protection

*Subject to payload

Ordering information

Product code	Product description
JPT-PSEARCHER-FB	Jaegar Searcher, Black
JPT-PSEARCHER-FW	Jaegar Searcher, White
JPT-HSEARCHER-FB	Jaegar HD Searcher, Black
JPT-HSEARCHER-FW	Jaegar HD Searcher, White

Dimensions (in millimeters)

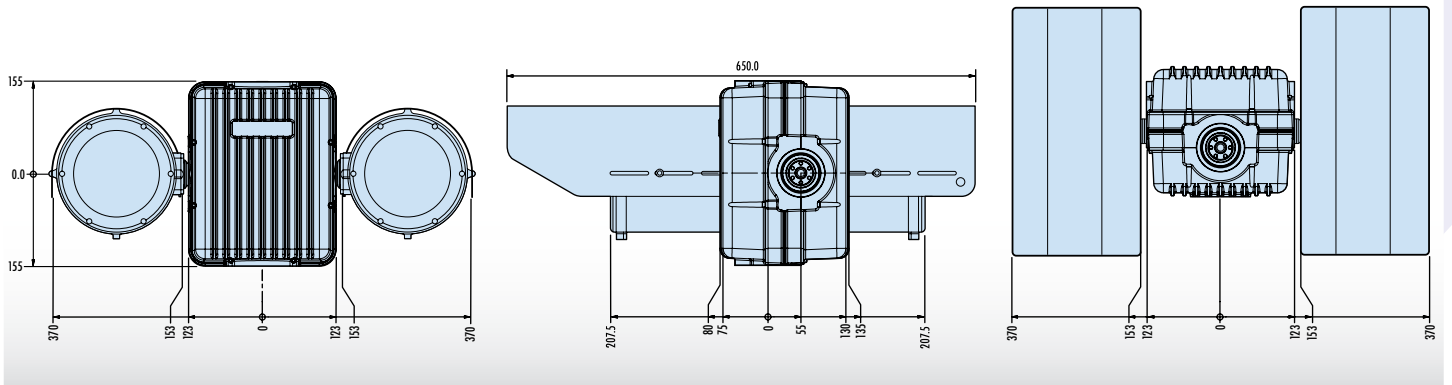

Detection, Recognition and Identification range charts

DB type thermal

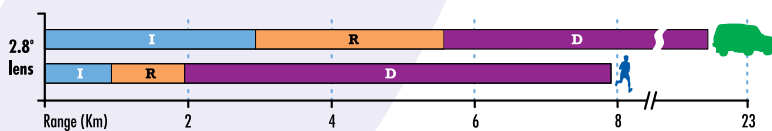

Key to Johnson's Criteria charts

- D** Detection - an object is present (-2 pixels)
- R** Recognition - the object can be discerned (- 8 pixels)
- I** Identification - the object can be identified e.g. male versus female, a specific car (- 12.8 pixels)

Note: Ranges may vary depending on atmospheric conditions

Tower mount bracket

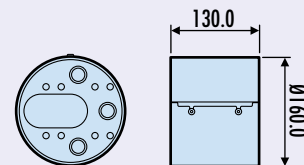

Designed and manufactured in the UK.

Specifications may be subject to change without notice • DN140814 - 1.1c • © 2014